



NOTE: This document is intended **only as a quick reference for installation** – please read the following SP Controls Application Note for a complete description of this projector driver prior to installation.

## I. Driver Features

### 1. Input Selection Mapping

Selection 1:	COMPUTER 1
Selection 2:	COMPUTER 2
Selection 3:	S-VIDEO
Selection 4:	VIDEO

### 2. Hidden Function Mapping

Selection 1:	ALL MUTE ON
Selection 2:	ALL MUTE OFF
Selection 3:	ADJUST LEFT
Selection 4:	ADJUST RIGHT
Off:	MENU / SELECT
Volume Up:	ADJUST UP
Volume Down:	ADJUST DOWN

### 3. Other Driver Features

Power Status Feedback Method	None (see note 1)
Control Wiring Option	RS232 and IR Emitter

## II. Wiring Specifications

NOTE: For a wiring diagram, please see the following Application Note

### 1. RS-232:

If you separately ordered the Toshiba RS-232 adapter cable, wire the Panel RS-232 port to a male DB9 as follows:

RX to	2
TX to	3
GND to	5

Otherwise, terminate the RS-232 control cable from the Panel directly on an 8-pin mini-DIN as follows:

RX to	7
TX to	1
GND to	4

Connect the RS-232 cable to the projector port labeled CONTROL

### 2. Infrared Emitter:

Wire the Panel IR/Serial port to a female 1/8" Mini as follows:

IR/SER to	tip
GND to	ring

Attach to any projector IR port using the Panel's IR Emitter (included with the Panel).

## III. Additional Notes

In order for the SmartPanel to properly control the Toshiba some settings on the projector need to be set. Set the following options on the projector:

1. *Power On* – In the Default Settings menu set the *Power On* option to **MANUAL**.
2. *Auto Input Search* – In the Default Settings menu set the *Auto Input Search* option to **OFF**.
3. *Startup Screen* – In the Display Settings menu set the *Startup Screen* option to **OFF**.
4. *Icon* – In the Display Settings menu set the *Icon* option to **OFF**.



# Projector Driver Application Note

## Toshiba TDP-T90

### Revision A

**Note:** The Toshiba projector requires an RS-232 control cable which does not ship with the projector and must be separately ordered. Alternately, you can terminate your RS-232 control cable on a standard 8-pin mini-DIN male connector. See *Section II. Control Wiring* for more information.

**Note:** The Toshiba projector requires several menu settings in order to work properly with the SmartPanel. See the *Special Control Note* in *Section II: Control Wiring* for more information.

## I. PROJECTOR CONTROL

### A. Volume and Power Control

Volume control on the Toshiba is **relative**. Absolute volume control for this model is possible with use of SP Controls' optional **Audio Follow Video Pre-Amplifier**.

### B. Input Selection Mapping

The following table specifies the factory preset input mapping for this Driver. The **Configuration Utility** can be used to customize these settings your installation.

Selection 1:	COMPUTER 1
Selection 2:	COMPUTER 2
Selection 3:	S-VIDEO
Selection 4:	VIDEO

Input choices available with this Driver are COMPUTER 1, COMPUTER 2, VIDEO, and S-VIDEO.

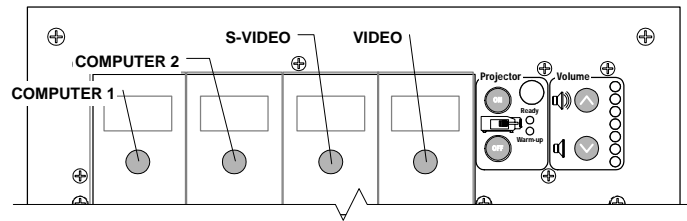

### C. Hidden Function Mapping

The following table specifies the factory preset hidden function mapping for this Driver. The **Configuration Utility** can be used to customize these settings your installation.

Selection 1:	ALL MUTE ON
Selection 2:	ALL MUTE OFF
Selection 3:	ADJUST LEFT
Selection 4:	ADJUST RIGHT
Off:	MENU / SELECT
Volume Up:	ADJUST UP
Volume Down:	ADJUST DOWN

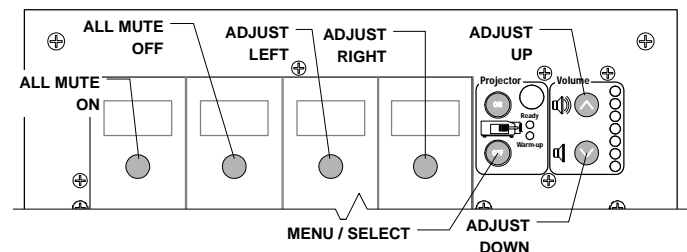

Hidden functions names are based on Toshiba documentation. *Adjust* controls navigate through onscreen menus. Hidden functions are accessed by pressing the indicated key while the holding the **On** key down.

The hidden functions available for the Toshiba with this Driver are as follows. Note that the functions available will vary depending on the model of projector you are controlling:

ALL MUTE ON/OFF is an A/V Mute.

MENU / SELECT  
 ADJUST LEFT  
 ADJUST RIGHT  
 ADJUST UP

KEYSTONE+  
 KEYSTONE-  
 ADJUST DOWN  
 AUTO KEYSTONE

ALL MUTE ON  
 ALL MUTE OFF  
 FREEZE ON  
 FREEZE OFF

**D. Relays**

The following table specifies the factory preset settings for the low-current relays found on the rear of the **SmartPanel**. The **Configuration Utility** can be used to customize these settings your installation.

Relay 1	ON Maintained
Relay 2	ON Momentary
Relay 3	OFF Momentary
Selection	Momentary; not Binary

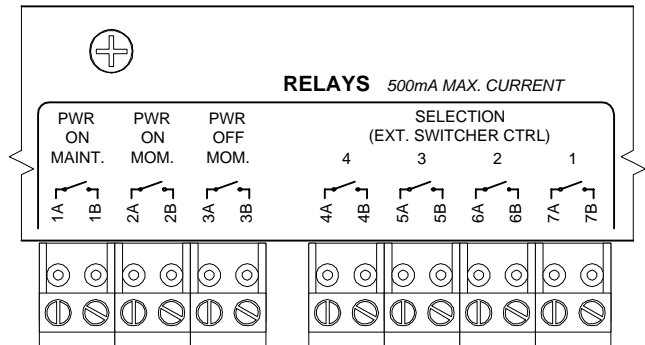

**E. Other Presets**

The following table specifies other default factory settings for this Driver that affect is control of the Projector.

<i>Power Status Feedback Method</i>	None (see note 1)
<i>Control Wiring Option</i>	RS-232 and IR Emitter

Control for the Toshiba with this Driver is via RS-232 and IR Emitter. The projector does not have a wired remote port. Power polling is not available for this projector.

The following table specifies settings for the Panel's configurable timers. For more information on the inactivity shutdown feature and the lockout timer see the *SmartPanel Configuration and Installation Guide*.

Lockout Timer	75 seconds (see note 3)
Inactivity Shutdown	Disabled

## II. CONTROL WIRING

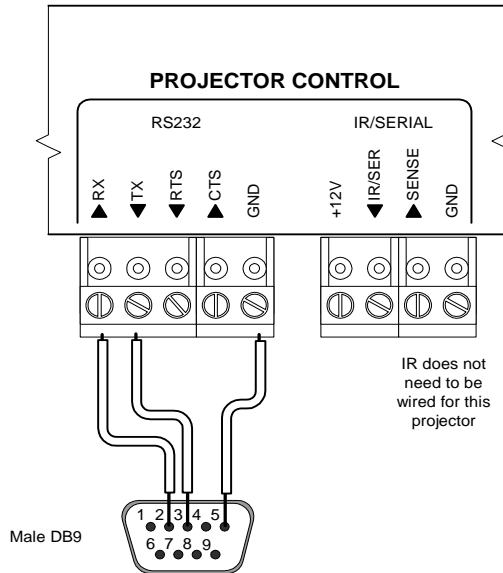

This section specifies how RS-232 should be wired to the projector. RS-232 should be connected to the control port labeled **CONTROL**. Connection should be as follows:

1. Wire the Panel to a male DB9 as follows:  
RX to 2  
TX to 3  
GND to 5
2. Connect the DB9 to the Toshiba RS-232 adaptor cable (must be separately ordered from Toshiba).
3. Alternately, you can terminate the RS-232 control cable from the Panel in a standard 8-pin mini-DIN (male). Pinouts are as follows:

PANEL	miniDIN
RX	7
TX	4
GND	1

4. Connect the mini-DIN to the Mitsubishi projector port labeled RS-232C.

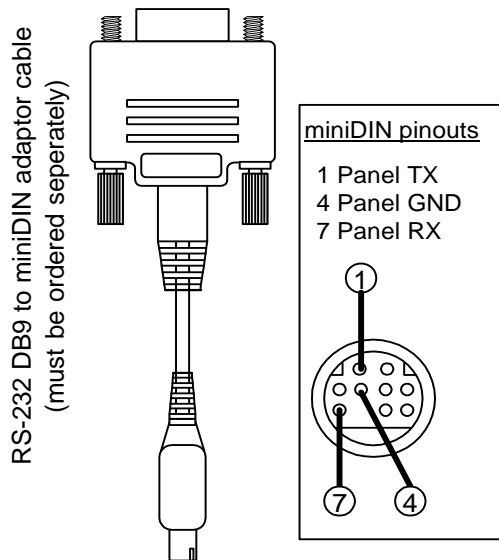

### SPECIAL CONTROL NOTE:

In order for the SmartPanel to properly control the Toshiba some settings on the projector need to be set. Set the following options on the projector:

1. *Power On* – In the Default Settings menu set the *Power On* option to **MANUAL**.
2. *Auto Input Search* – In the Default Settings menu set the *Auto Input Search* option to **OFF**.
3. *Startup Screen* – In the Display Settings menu set the *Startup Screen* option to **OFF**.
4. *Icon* – In the Display Settings menu set the *Icon* option to **OFF**.

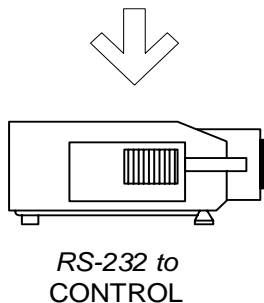

### III. TROUBLESHOOTING

Additional tips can be found in the *SmartPanel Configuration and Installation Guide*.

*The Panel does not power the projector on.*

The projector on-screen menus must be configured so its *Standby Mode* is set to *Standard*. See the *Special Control Note* in *Section II, Control Wiring* above.

*The Panel does not do anything at all.*

When power is applied to the Panel it should run through a brief power on self-test, during which all of the Panel lights will turn on and off in sequence. If you do not see this self-test, make sure power is connected correctly and that polarity is correct.

*Only some of the projector controls work.*

The Panel controls the Toshiba through RS-232 and IR. If only a subset of the controls is working, verify that both types of control wiring are correctly wired.

*The Panel keeps turning itself off even though the projector is on.*

The Panel turns itself off when power verification indicates that the projector is off. Check to make sure that any third-party power current sensor is correctly calibrated and wired to the Panel.

*When I try to turn the projector on, the warming indicator (red LED) blink.*

The projector is in the default configured *lockout state*, and the Panel is waiting for its internal lockout timer to expire. This feature protects the projector's bulb. Be sure to let your client know about this behavior.

### IV. TECHNICAL NOTES

1. The Toshiba projector does not allow power verification by RS-232 polling. A third party power current sensor is recommended.
2. Control of this projector is through RS-232 and Infrared.
3. The lockout timer specifies the amount of time allowed between sending *POWER OFF* and *POWER ON* to the projector (the delay allows the projector bulb to cool before re-powering). This delay can be configured using the **Configuration Utility**; however, adjusting the lockout timer delay is **strongly discouraged** as rapid re-powering causes undue wear on the projector's bulb. **Disabling the lockout delay will cause potentially confusing Panel behavior.**

### V. REVISION HISTORY

1. Revision A (November, 2004)