



**NOTE:** This one-page document is intended **only as a quick reference for installation** – please read the SP Controls Application Note for a complete description of this projector driver prior to installation.

## I. Driver Features

### 1. Input Selection Mapping

Selection 1:	VGA
Selection 2:	INPUT1-VID
Selection 3:	INPUT2-SVID
Selection 4:	INPUT3

### 2. Hidden Function Mapping (Default Configuration)

Using the ON button as a shift key, press the following buttons to access the specified projector features.

Selection 1:	RETURN
Selection 2:	ENTER
Selection 3:	ADJ LEFT
Selection 4:	ADJ RIGHT
Off:	MENU
Volume Up:	ADJ UP
Volume Down:	ADJ DOWN

### 3. Other Driver Features

Power Status Feedback Method	NONE
Control Wiring:	RS-232 and IR-Emitter

## II. Wiring Specifications

NOTE: For a wiring diagram, please see the SP Controls Application Note.

### 1. RS-232:

Wire the Panel RS-232 port to a female DB9 as follows:

TX to	2
RX to	3
GND to	5

Connect this female DB9 the control port labeled *RS-232C*.

### 2. Infrared Emitter:

Wire the Panel IR/Serial port to a female 1/8" Mini as follows:

IR/SER to	<i>tip</i>
GND to	<i>ring</i>

Connect to the included IR Emitter and attach the emitter bud to any projector IR window.



This document describes the **SmartPanel** Projector Driver for the **Sharp LC-M3700** projector. For information on configuring and using the Panel see the *SmartPanel Configuration and Installation Guide*.

## I. PROJECTOR CONTROL

### A. Volume and Power Control

Volume control on the Sharp is **absolute**. Absolute volume control is also possible with SP Controls' option **Audio Follow Video Preamplifier** (SP3-AFVP+).

NOTE: When controlling volume with the SmartPanel the minimum volume level is 10.

### B. Input Selection Mapping

The following table specifies the factory-preset input mapping for this Driver. The **Configuration Utility** can be used to customize these settings your installation.

<i>Selection 1:</i>	VGA
<i>Selection 2:</i>	INPUT1-VID
<i>Selection 3:</i>	INPUT2-SVID
<i>Selection 4:</i>	INPUT3

Input choices available for the Sharp with this Driver are INPUT1-VID, INPUT1-SVID, INPUT2-VID, INPUT3, VGA, and DVI.

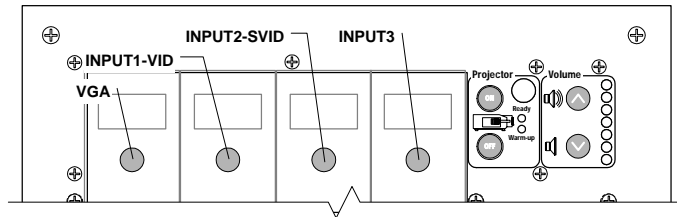

### C. Hidden Function Mapping

The following table specifies the factory preset hidden function mapping for this Driver. The **Configuration Utility** can be used to customize these settings your installation.

<i>Selection 1:</i>	RETURN
<i>Selection 2:</i>	ENTER
<i>Selection 3:</i>	ADJUST LEFT
<i>Selection 4:</i>	ADJUST RIGHT
<i>Off:</i>	MENU
<i>Volume Up:</i>	ADJUST UP
<i>Volume Down:</i>	ADJUST DOWN

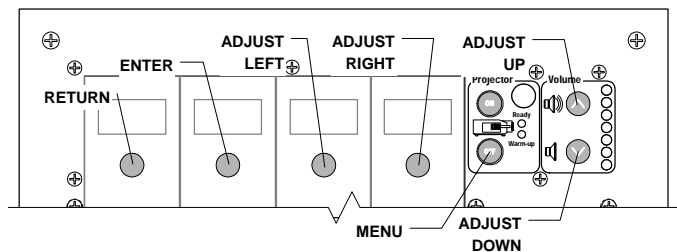

Hidden functions names are based on the Sharp. Hidden functions are accessed by pressing the indicated key while the holding the **On** key down.

*ADJUST* controls, *ENTER* and *RETURN* navigate through onscreen menus. *RETURN* is a "return to previous menu" or "back" command. *MENU* can also be used as *RETURN*.

The hidden functions available for the Sharp with this Driver are as follows:

MENU	ENLARGE	ADJUST UP
ADJUST LEFT	ENTER	ADJUST DOWN
ADJUST RIGHT	WIDE	RETURN

**D. Relays**

The following table specifies the factory preset settings for the low-current relays found on the rear of the **SmartPanel**. The **Configuration Utility** can be used to customize these settings your installation.

Relay 1	ON Maintained
Relay 2	ON Momentary
Relay 3	OFF Momentary
Selection	Momentary; not Binary

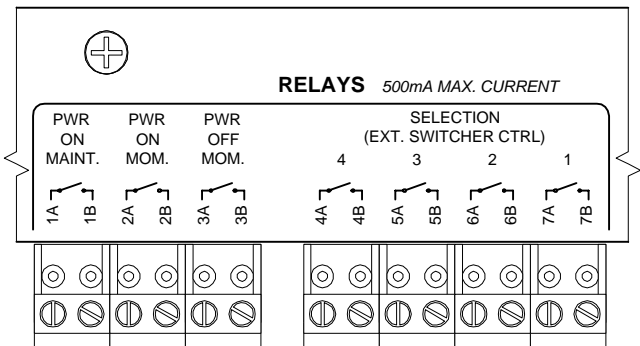

**E. Other Presets**

The following table specifies other default factory settings for this Driver that affect is control of the Projector.

<i>Power Status Feedback Method</i>	None (see note 1)
<i>Control Wiring</i>	RS-232 and Infrared Emitter (see note 2)

Control for the Sharp with this Driver is via RS-232 and Infrared Emitter

The following table specifies settings for the Panel's configurable timers. For more information on the inactivity shutdown feature and the lockout timer see the *SmartPanel Configuration and Installation Guide*.

Lockout Timer	5 seconds (see note 3)
Inactivity Shutdown	Disabled

## II. CONTROL WIRING

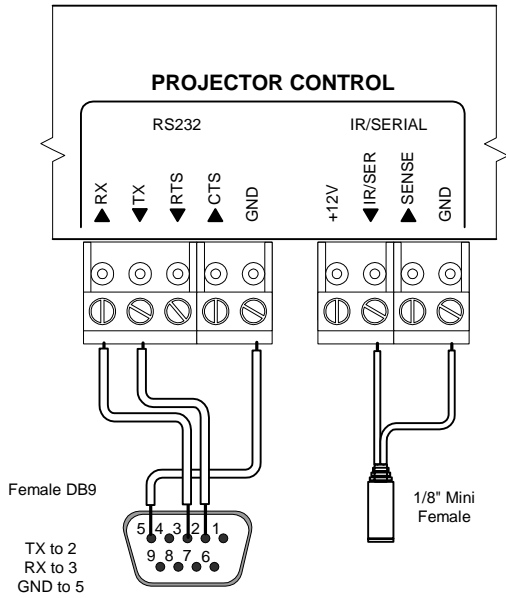

This section specifies how RS-232 and the Infrared Emitter should be wired to the Sharp projector.

**A.** RS-232 should be connected to the Sharp control port labeled **RS-232C**. Connection should be as follows:

1. Wire the Panel to a female DB9 as follows:
  - TX to 2
  - RX to 3
  - GND to 5
2. Connect the cable to the control port labeled *RS-232C*.

**B.** Infrared should be wired to any Sharp infrared port. Connection should be as follows:

1. Wire the Panel to a female 1/8" Mini as shown; wire *IR/SER* to *tip* and *GND* to *ring*. Direct wiring to the IR Emitter is not recommended as it makes removal of the Panel for service more difficult.
2. Attach to any projector IR port using the Panel's IR Emitter (included with the Panel).

Note that the emitter glows red when IR is emitted so wiring can be verified.

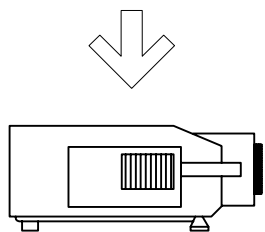

RS-232 to  
RS-232C

IR Emitter to  
any window

### III. TROUBLESHOOTING

Additional tips can be found in the *SmartPanel Configuration and Installation Guide*.

*The Projector keeps turning itself off!*

Verify that the A20X's *Economy Mode* is set to *OFF* as explained in the Special Note in the *Control Wiring* section of this document. If the *Economy Mode* is on, the projector will shut itself off after fifteen minutes. If power polling or a third party power current sensor is being used (e.g., AMX-PCS), the Panel will automatically shut itself off also. If not, the Panel will remain on and you will have to power the Panel off with the *Off* button and wait until the lockout timer expires before you can re-power the projector.

*The Panel does not do anything at all.*

When power is applied to the Panel it should run through a brief power on self-test, during which all of the Panel lights will turn on and off in sequence. If you do not see this self test, make sure power is connected correctly and that polarity is correct.

*The Panel keeps turning itself off even though the projector is on.*

The Panel turns itself off when power status feedback indicates that the projector is off. If a third party power current sensor is being used, check to make sure that it is correctly wired, and that it is correctly calibrated according to the manufacturer's instructions. If not, make sure that the Panel is configured with *None* or *Power Polling* under power status feedback in the Configuration Utility's *Wiring Options* tab.

### IV. TECHNICAL NOTES

1. By default, projector power is verified by polling every few seconds via the RS-232 port. Power polling can be suspended by depressing and holding the **On** key; polling will be restored when the key is released. Should the Sharp power off, the Panel will usually detect this condition and power off within twenty seconds. Should the Sharp power on, the Panel will usually detecting this condition and power on within ten seconds.
2. The Sharp is controlled via RS-232 and Infrared/Wired Remote with this Driver. A discussion of the advantages of Wired Remote versus IR can be found in the *SmartPanel Configuration and Installation Guide*.
3. The lockout timer specifies the amount of time allowed between sending *POWER OFF* and *POWER ON* to the projector (the delay allows the projector bulb to cool before re-powering). This delay can be configured using the **Configuration Utility**; however, adjusting the lockout timer delay is **strongly discouraged** as rapid re-powering causes undue wear on the Sharp. Also, the Sharp will **not** allow power to be restored before a minimum delay has expired. Therefore, **disabling the lockout delay will cause potentially confusing Panel behavior**.

### V. REVISION HISTORY

1. Revision A (May, 2004) *Original release*.